

Product Specification

Polymer Li-ion

11.1v 3000 mah

(For high discharge ratio battery)



AA Portable Power Corp

2700 Rydin Road, Unit C Richmond, CA, 94804, USA

Tel: 510-252-2328

Fax: 510-439-2808

All 6 Sheets

AA Portable Power Corp http://www.batteryspace.com	Doc. No.	16-01-2007
	Edition No.	1.0
	Sheet	1/6

1、Scope:

This product specification describes Wanna polymer lithium-ion battery. Please using the test methods that recommend in this specification. If you have any opinions or advices about the test items and methods, please contact us. Please read the cautions recommended in the specifications first, take the credibility measure of the cell's using.

If the cells should be using at the environment that not preferred in this document, please connect with our first and get our authorization.

It is claimed that we should have no any responsibility with the contingency and loss due to the cells' wrong usage (not preferred in the product specification).

2、Product Type, Model and Dimension:

2.1 Type: Polymer lithium-ion battery

2.2 Model: 6045135U (3SCell adding PCB, wire, plugs)

2.3 Cell Dimension(Max, Thickness×Width×Length, mm³): 6.0×45.2×136.0

Pack Dimension(Max, Thickness×Width×Length, mm³): 25.0x52.0x146.0

3、Specification:

Item	Specifications	Remark
Nominal Capacity	<u>3100</u> mAh	0.2C ₅ A discharge
Typial Capacity	<u>3000</u> mAh	0.2C ₅ A discharge
Nominal Voltage	11.1V	Average Voltage at 0.2C ₅ A discharge
Charge Current	Standard: 0.2 C ₅ A; Max: 1C ₅ A	Working temperature: 0~45℃
Charge cut-off Voltage	12.6±0.05V	
Discharge Current	Continuously: 15C ₅ A; Max: 20C ₅ A	Working temperature: 0~60℃
Discharge cut-off Voltage	8.25V	
Cell Voltage	11.1~11.7V	When leave factory
Impedance	≤ <u>80</u> mΩ	AC 1KHz after 50% charge
Weight	Approx <u>240</u> g	
Storage temperature	≤1month	-20~45℃
	≤3month	0~30℃
	≤6month	20±5℃
Storage humidity	65±20% RH	Best 20±5℃ for long-time storage

4、General Performance:

Definition of Standard charging method: At 20±5℃, charging the cell initially with constant current 0.2C₅A till voltage 12.6V, then with constant voltage 12.6V till current declines to 0.05C₅A.

Item	Test Methods	Performance
4.1	0.2C Capacity	After standard charging, laying the battery 0.5h, then discharging at 0.2C ₅ A to voltage 8.25V, recording the discharging time.
8.6	15C Discharge	After standard charging, laying the battery 0.5h, then discharging at 15C ₅ A to voltage 8.25V, recording the discharging time.
4.3	Cycle Life	Constant current 1C ₅ A charge to 12.6V, then constant voltage charge to current declines to 0.05C ₅ A, stay 5min, constant current 1C ₅ A discharge to 8.25V, stay 5min. Repeat above steps till continuously discharging time less than 36min.
4.4	Capability of keeping electricity	20±5℃, After standard charging, laying the battery 28days, discharging at 0.2C ₅ A to voltage 8.25V, recording the discharging time.

AA Portable Power Corp http://www.batteryspace.com	Doc. No.	16-01-2007
	Edition No.	1.0
	Sheet	2/6

5、Environment Performance:

Item		Test Methods	Performance
5.1	High temperature	After standard charging, laying the battery 4h at 60℃, then discharging at 0.2C ₅ A to voltage 8.25V, recording the discharging time.	≥270min
5.2	Low temperature	After standard charging, laying the battery 4h at -20℃, then discharging at 0.2C ₅ A to voltage 8.25V, recording the discharging time.	≥210min
5.3	Constant humidity and temperature	After standard charging, laying the battery 48h at 40±2℃, RH 93±2%. Recording 0.2C ₅ A discharging time	No distortion No electrolytes leakage ≥270 min
5.4	Temperature shock	After standard charging, battery stored at -20℃ for 2 hours, then stored at 50℃ for 2 hours. Repeat 10 times.	No electrolytes leakage

6、Mechanical Performance:

Item		Test Methods	Performance
6.1	Vibration	After standard charging, put battery on the vibration table. 30 min experiment from X,Y,Z axis. Scan rate: 1 oct/min; Frequency 10-30Hz, Swing 0.38mm; Frequency 30-55Hz, Swing 0.19mm.	No influence to batteries' electrical performance and appearance.
6.2	Collision	After vibration test, batteries were laying on the vibration table about X, Y, Z axis. Max frequency acceleration: 100m/s ² ; collision times per minutes: 40~80; frequency keeping time 16ms; all collision times 1000±10.	No influence to batteries' electrical performance and appearance.
6.3	Drop	Random drop the battery from 10m height onto concrete one times.	No explosion or fire

7、Safety Test:

Test conditions: The following tests must be measured at flowing air and safety protection conditions. All batteries must standard charge and lay 24h.

Item		Test Methods	Performance
7.1	Over charge	At 20±5℃, charging batteries with constant current 3C ₅ A to voltage 14.4V, then with constant voltage 14.4V till current decline to 0. Stop test till batteries' temperature 10℃ lower than max temperature.	No explosion or fire
7.2	Over discharge	At 20 ± 5℃, discharge battery with 0.2C ₅ A continuously 12.5h.	No explosion or fire
7.3	Short-circuit	At 20±5℃, connect batteries' anode and cathode by wire which impedance less than 50mΩ, keep 6h.	No explosion or fire
22.2	Extrusion	At 20±5℃, put the battery in two parallel steel broad, add pressure 13kN.	No explosion or fire
7.5	Thermal shock	Put the battery in the oven. The temperature of the oven is to be raised at 5±1℃ per minute to a temperature of 130±2℃ and remains 60 minutes.	No explosion or fire

AA Portable Power Corp http://www.batteryspace.com	Doc. No.	16-01-2007
	Edition No.	1.0
	Sheet	3/6

8、Cautions:

8.1 Cautions of batteries' operation

The batteries must be careful of proceed the operation for it's soft package.

8.1.1 Aluminum packing materials

The aluminum packing material was easily damaged by the sharp edge part, such as nickel-tabs.

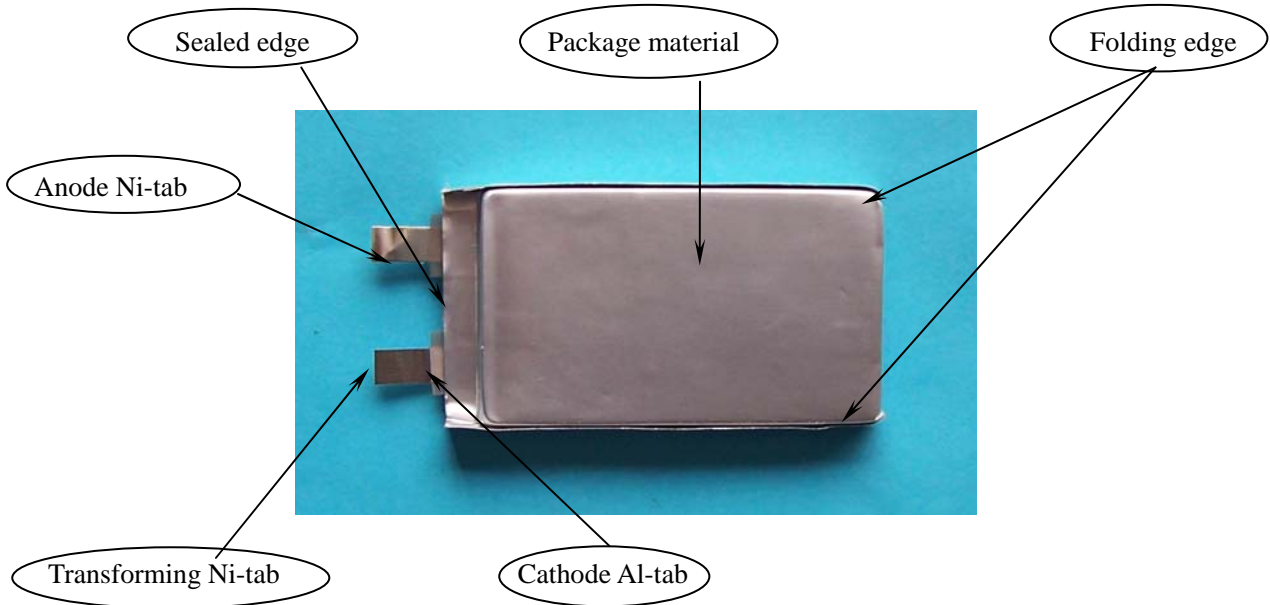

Fig.1. Exterior schematic of polymer lithium-ion cells

- (1) Forbid to use the sharp part touching the battery;
- (2) Should cleaning working condition, avoiding the sharp edge part existence;
- (3) Forbid to pierce the battery with nail and other sharp items;
- (4) The battery was forbidden with metal, such as necklace, hairpin etc in transportation and storage.

8.1.2 Sealed edge

Sealing edge is very easily damaged and don't bend it.

The Al interlayer of package has good electric performance. It's forbidden to connect with exterior component for preventing short-circuits.

8.1.3 Folding edge

The folding edge is formed in batteries' processes and passed all hermetic tests, don't open or deform it. The Al interlayer of package has good electric performance. It's forbidden to connect with exterior component for preventing short-circuits.

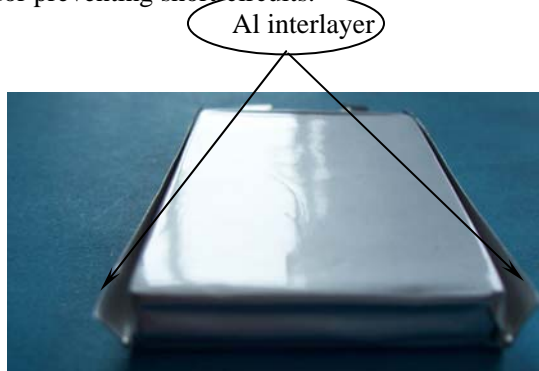

Fig.2. Single folding edge schematic of PL cells

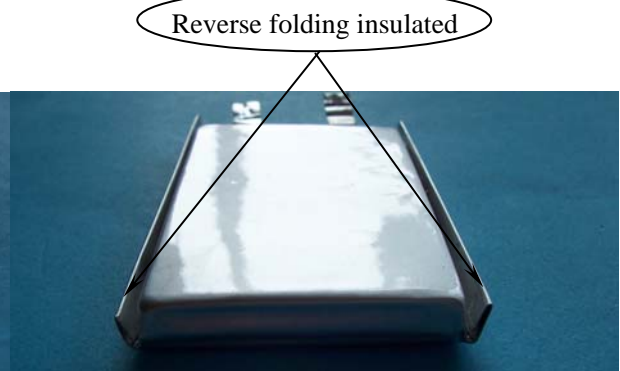

Fig.3. Reverse folding edge schematic of PL cells

8.1.4 Tabs

The batteries' tabs are not so stubborn especially for aluminum tabs. Don't bend tabs.

8.1.5 Mechanical shock

Don't fall, hit, bent the batteries' body.

AA Portable Power Corp http://www.batteryspace.com	Doc. No.	16-01-2007
	Edition No.	1.0
	Sheet	4/6

8.1.6 Short-circuit

Short-circuit is strictly prohibited. It should damage batteries badly.

8.2 Standard Test Environment for polymer lithium-ion batteries

Environment temperature: $20 \pm 5^{\circ}\text{C}$

Humidity: 45-85%

8.3 Cautions of charge & discharge

8.3.1 charge

Charging current should be lower than values that recommend below. Higher current and voltage charging may cause damage to cell electrical, mechanical, safety performance and could lead heat generation or leakage.

- (1) Batteries charger should charging with constant current and constant voltage mode;
- (2) Charging current should be lower than (or equal to) $1C_5A$;
- (3) Temperature $0 \sim 45^{\circ}\text{C}$ is preferred when charging;
- (4) Charging voltage must be lower than 12.65V.

8.3.2 discharge

- (1) Discharging current must be lower than (or equal to) $20C_5A$;
- (2) Temperature $0 \sim 60^{\circ}\text{C}$ is preferred when discharging;
- (3) Discharging voltage must not be lower than 8.25V.

8.3.3 over-discharge

It should be noted that the cell would be at an over-discharge state by its self-discharge. In order to prevent over-discharge, the cell shall be charged periodically to keeping voltage between 10.8-11.7V. Over-discharge may cause loss of cell performance. It should be noted that the cell would not discharge till voltage lower than 7.5V.

22.2 Storage of polymer lithium-ion batteries

The environment of long-time storage:

Temperature: $20 \pm 5^{\circ}\text{C}$;

Humidity: 45-85%;

Batteries were $40 \sim 60\%$ charged.

The battery had better charge a time per three month during its storage for avoiding over discharge. If storage is long time, please charge the battery with constant current $0.5C_5A$ for 1 hour so that it has some storage of charge for properly using.

Charge and discharge afresh to active and renew battery energy after storage above 1 year.

8.5 Transportation of polymer lithium-ion batteries

The batteries should transportation with $10 \sim 50\%$ charged states.

8.6 Others

Please note cautions below to prevent cells' leakage, heat generation and explosion.

Prohibition of disassembly cells;

Prohibition of cells immersion into liquid such as water or seawater;

Prohibition of dumping cells into fire;

Prohibition of using damaged cells. The cells with a smell of electrolyte or leakage must be placed away from fire to avoid firing.

In case of electrolyte leakage contact with skin, eye, physicians shall flush the electrolyte immediately with fresh water and medical advise is to be sought.

9、 Notice of Designing Battery Pack:

9.1 Pack design

Battery pack should have sufficient strength and battery should be protected from mechanical shock. No sharp edge components should be inside the pack contain the battery.

9.2 PCM design

The overcharge threshold voltage should not be exceed 4.25V.

The over-discharge threshold voltage should not be lower than 2.3V.

The PCM should have short protection function built inside.

9.3 Tab connection

Ultrasonic welding or spot welding is recommended to connect battery with PCM or other parts.

If apply manual solder method to connect tab with PCM, the notice below is very important to ensure

AA Portable Power Corp http://www.batteryspace.com	Doc. No.	16-01-2007
	Edition No.	1.0
	Sheet	5/6

battery performance.

- (1) The electric iron should be temperature controlled and ESD safe;
- (2) Soldering temperature should not exceed 350°C;
- (3) Soldering time should not be longer than 3s, keep battery tab cold down before next soldering;
- (4) Soldering times should not exceed 5 times;
- (5) Directly heat cell body is strictly prohibited, battery may be damaged by heat above approx. 100°C.

9.4 Cell fixing

The battery should be fixed to the battery pack by its large surface area. No cell movement in the battery pack should be allowed.

9.5 Cells replacement

The cell replacement should be done by professional people. Prohibit short-circuit between cells' Al package and exterior component.

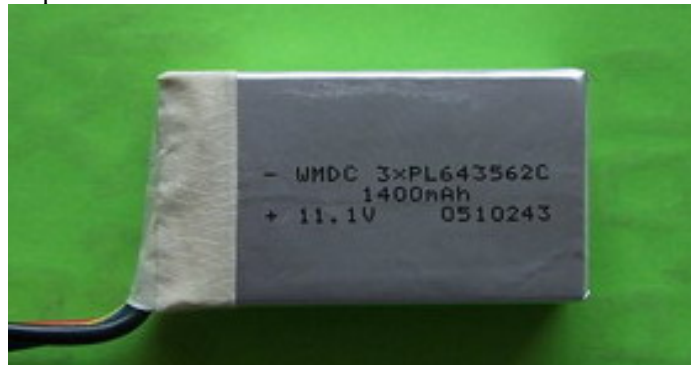
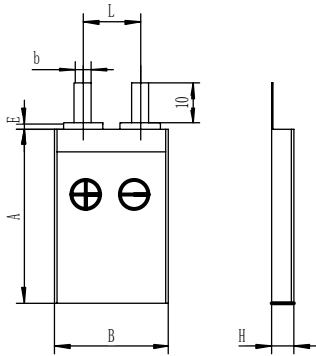
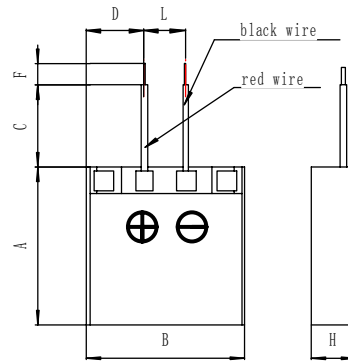

Fig.4. Protect schematic of transforming component connecting with cell

10. Schematic of Battery:



Cell or adding Ni tabs



Cell adding PCB, wire

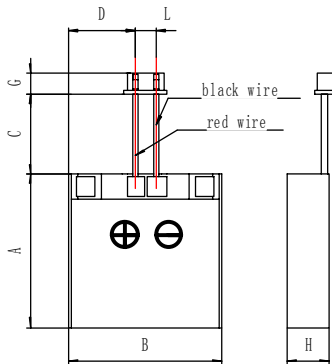

✓ Cell adding PCB, wire, plugs

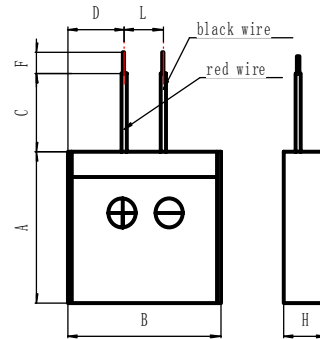

Cell adding wire

Parameter: ✓

Sign	Item	Max (mm)	Remak	Sign	Item	Max (mm)	Remak
A	Length	145.0		L	Space between Tabs	/	
B	Width	47.0		E	PP membrane Length	/	
H	Thickness	21.5		b	Tab Width	/	
	Wire Standard	AWG14#*130			Plug Standard	XH-4P	